

OWNER'S MANUAL | MANUEL DE L'UTILISATEUR  
MANUAL DEL PROPIETARIO | HANDBUCH | MANUALE DELL'UTENTE

MODEL / MODÈLE / MODELO / MODELL / MODELLO : PB150PPS  
PART / PIÈCE / PARTE / TEIL / PARTE : 10805



# PIT BOSS® NAVIGATOR PB150PPS



## WOOD PELLET GRILL & SMOKER

IMPORTANT, READ CAREFULLY, RETAIN FOR FUTURE REFERENCE. MANUAL MUST BE READ BEFORE OPERATING!

## FUMOIR ET GRIL À GRANULÉS DE BOIS

IMPORTANT, PRENEZ CONNAISSANCE DE CE DOCUMENT ET CONSERVEZ-LE POUR RÉFÉRENCE ULTÉRIEURE. VOUS DEVEZ LIRE CE GUIDE AVANT D'UTILISER LE BARBECUE!

## PARRILLA Y AHUMADOR DE PELLETS DE MADERA

IMPORTANTE, LEER DETENIDAMENTE, CONSERVAR PARA REFERENCIA FUTURA. LEA EL MANUAL ANTES DEL USO!

## HOLZPELLET-GRILL UND SMOKER

WICHTIG: AUFMERKSAM LESEN UND GUT AUFBEWAHREN BITTE UNBEDINGT VOR GEBRAUCH DIE BEDIENUNGSANLEITUNG SORGFÄLTIG DURCHLESEN!

## GRIGLIA A PELLETTI DI LEGNO CON AFFUMICATORE

IMPORTANTE: LEGGERE ATTENTAMENTE E CONSERVARE PER RIFERIMENTO FUTURO. LEGGERE IL MANUALE PRIMA DELL'USO.

**WARNING:** PLEASE READ THE ENTIRE MANUAL BEFORE INSTALLATION AND USE OF THIS ELECTRIC, PELLET FUEL-BURNING APPLIANCE. FAILURE TO FOLLOW THESE INSTRUCTIONS COULD RESULT IN PROPERTY DAMAGE, BODILY INJURY OR EVEN DEATH. CONTACT LOCAL BUILDING OR FIRE OFFICIALS ABOUT RESTRICTIONS AND INSTALLATION INSPECTION REQUIREMENTS IN YOUR AREA.

**AVERTISSEMENT :** VEUILLEZ LIRE L'INTÉGRALITÉ DU MANUEL AVANT L'INSTALLATION ET L'UTILISATION DE CET APPAREIL ÉLECTRIQUE À COMBUSTION DE GRANULÉS DE BOIS. LE NON-RESPECT DE CES INSTRUCTIONS PEUT ENTRAÎNER DES DOMMAGES MATÉRIELS, DES DOMMAGES CORPORELS OU MÊME LA MORT. CONTACTEZ LES AUTORITÉS LOCALES COMPÉTENTES CONCERNANT LES RESTRICTIONS ET LES EXIGENCES D'INSPECTION EN VIGUEUR DANS VOTRE RÉGION.

**ADVERTENCIA:** LEA TODO EL MANUAL ANTES DE INSTALAR Y USAR ESTA UNIDAD QUE FUNCIONA CON ELECTRICIDAD Y COMBUSTIÓN DE PELLETS. SI NO SE SIGUEN ESTAS INSTRUCCIONES, PUEDEN PRODUCIRSE DAÑOS MATERIALES, LESIONES CORPORALES O INCLUSO LA MUERTE. PARA CONSULTAR LAS RESTRICCIONES Y REQUISITOS DE INSPECCIÓN DE LAS INSTALACIONES DE SU ZONA, PÓNGASE EN CONTACTO CON LOS ENCARGADOS DE EDIFICIO O EL DEPARTAMENTO DE BOMBEROS.

**ACHTUNG:** BITTE LESEN SIE DIE GESAMTE ANLEITUNG SORGFÄLTIG DURCH, BEVOR SIE DIESE ELEKTRISCHE, PELLETTBEFEUERTER GERÄT INSTALLIEREN UND BENUTZEN. DIE NICHTBEACHTUNG DIESER ANWEISUNGEN KANN ZU SACHSCHÄDEN, KÖRPERVERLETZUNGEN ODER Sogar ZUM TOD FÜHREN. WENDEN SIE SICH AN LOKALE BAU- ODER BRANDSCHUTZBEHÖRDEN, UM INFORMATIONEN ÜBER EINSCHRÄNKUNGEN UND ANFORDERUNGEN AN DIE INSTALLATIONSINSPEKTION IN IHRER NÄHE ZU ERHALTEN.

**AVVERTENZA:** LEGGERE L'INTERO MANUALE PRIMA DELL'INSTALLAZIONE E DELL'USO DI QUESTA APPARECCHIATURA ELETTRICA PER LA COMBUSTIONE DI PELLETTI. LA MANCATA OSSERVANZA DELLE ISTRUZIONI PUÒ CAUSARE DANNI ALLA PROPRIETÀ, LESIONI FISICHE O MORTE. CONTATTARE LE AUTORITÀ LOCALI COMPETENTI PER L'EDILIZIA O I VIGILI DEL FUOCO PER INFORMAZIONI SULLE RESTRICZIONI E SUI REQUISITI DI ISPEZIONE DEGLI IMPIANTI NELLA PROPRIA ZONA.



For outdoor and household use only. Not for commercial use.  
Réservé à l'usage extérieur et résidentiel uniquement. Non destiné à un usage commercial.  
Solo para uso doméstico y en el exterior. No apto para uso comercial.  
Bitte nur im Freien und privat nutzen. Nicht für die gewerbliche Anwendung geeignet.  
Solo per uso domestico ed esterno. Non per uso commerciale.

# SAFETY INFORMATION

**MAJOR CAUSES OF APPLIANCE FIRES ARE A RESULT OF POOR MAINTENANCE AND A FAILURE TO MAINTAIN REQUIRED CLEARANCE TO COMBUSTIBLE MATERIALS. IT IS OF UTMOST IMPORTANCE THAT THIS PRODUCT BE USED ONLY IN ACCORDANCE TO THE FOLLOWING INSTRUCTIONS.**

Please read and understand this entire manual before attempting to assemble, operate or install the product. This will ensure you receive the most enjoyable and trouble-free operation of your new wood pellet grill. We also advise you retain this manual for future reference.

## DANGERS AND WARNINGS

**You must contact your local home association, building or fire officials, or authority having jurisdiction, to obtain the necessary permits, mission or information on any installation restrictions, such as any grill being installed on a combustible surface, inspection requirements or even ability to use, in your area.**

1. A minimum clearance of 305mm (12 inches) from combustible constructions to the sides of the grill, and 305mm (12 inches) from the back of the grill to combustible constructions must be maintained. **Do not install appliance on combustible floors, or floors protected with combustible surfaces unless proper permits and permissions are obtained by authorities having jurisdiction.** Do not use this appliance indoors or in an enclosed, unventilated area. This wood pellet appliance must not be placed under overhead combustible ceiling or overhang. Keep your grill in an area clear and free from combustible materials, gasoline and other flammable vapors and liquids.

**Should a grease fire occur, turn the grill OFF and leave the lid closed until the fire is out. Unplug the power cord from the connected outlet. Do not throw water on the unit. Do not try to smother the fire. Use of an all-class (class ABC) approved fire extinguisher is valuable to keep on site. If an uncontrolled fire does occur, call the Fire Department.**

2. Keep electrical supply cords and the fuel away from heated surfaces. Do not use your grill in the rain or around any water source. If the supply cord is damaged, it must be replaced by the manufacturer, its service agent or similarly qualified persons in order to avoid a hazard.
3. After a period of storage, or non-use, check the Burn Pot for obstructions, the hopper for foreign objects, and any air blockage around the fan intake, chimney, or rear barrel exhaust holes. Clean before use. Regular care and maintenance is required to prolong the lifespan of your unit. **If the grill is stored outside during the rainy season or seasons of high humidity, care should be taken to insure that water does not get into the hopper.** When wet or exposed to high humidity, wood pellets will expand greatly, decompose, and may jam the feed system. Always disconnect the power, before performing any service or maintenance.

**Do not transport your grill while in use or while the grill is hot. Ensure the fire is completely out and that the grill is completely cool to the touch before moving.**

4. It is recommended to use heat-resistant barbecue mitts or gloves when operating the grill. Do not use accessories not specified for use with this appliance. Do not put a barbecue cover or anything flammable in the storage space area under the barbecue.
5. To prevent fingers, clothing or other objects from coming in contact with the auger feed system, the appliance is equipped with a metal safety screen, mounted to the interior of the hopper. This screen must not be removed unless directed by Customer Service or an authorized dealer.

**This appliance can be used by children aged from 8 years and above and persons with reduced physical, sensory or mental capabilities or lack of experience and knowledge if they have been given supervision or instruction concerning use of the appliance in a safe way and understand the hazards involved. Children shall not play with the appliance. Cleaning and user maintenance shall not be made by children without supervision.**

6. Parts of the barbecue may be very hot and serious injury may occur. Keep young children and pets away while in use.
7. Do not enlarge igniter holes or Burn Pots. Failure to follow this warning could lead to a fire hazard and bodily harm and will void your warranty.
8. Product may have sharp edges or points. Contact may result in injury. Handle with care.

## DISPOSAL OF ASHES

Ashes should be placed in a metal container with a tight-fitting lid. The closed container of ashes should be placed on a non-combustible floor or on the ground, well away from all combustible materials, pending final disposal. When ashes are disposed by burial in soil, or otherwise locally dispersed, they should be retained in a closed container until all cinders have thoroughly cooled.

## WOOD PELLET FUEL

This pellet cooking appliance is designed and approved for pelletized, all natural, wood fuel only. Any other type of fuel burned in this appliance will void the warranty and safety listing. You must only use all natural wood pellets, designed for burning in pellet barbecue grills. Do not use fuel with additives. Wood pellets are highly susceptible to moisture and should always be stored in an airtight container. If you are storing your grill, without use, for an extended period, we recommend clearing all pellets from your grill's hopper and auger, to prevent jams. The pellet fuel mean heating value in 8000-8770 BTU/LB, ash content < 1%.

**Do not use spirit, petrol, gasoline, lighter-fluid or kerosene for lighting or refreshing a fire in your grill. Keep all such liquids well away from the appliance when in use.**

At time of printing, there is no industry standard for barbecue wood pellets, although most pellet mills use the same standards to make wood pellets for domestic use. Further information can be found at [www.pelletheat.org](http://www.pelletheat.org) or the **Pellet Fuel Institute**.

Contact your local dealer on the quality of pellets in your area and for information on brand quality. As there is no control over the quality of pellets used, we assume no responsibility to damage caused by poor quality of fuel.

## CREOSOTE

Creosote, or soot, is a tar-like substance. When burning, it produces black smoke with a residue which is also black in color. Soot or creosote is formed when the appliance is operated incorrectly, such as: blockage of the combustion fan, failure to clean and maintain the burn area, moisture affected pellets, or poor air-to-fuel combustion.

It is dangerous to operate this appliance should the flame become dark, sooty, or if the Burn Pot is overfilled with pellets. When ignited, this creosote makes an extremely hot and uncontrolled fire, similar to a grease fire. Should this happen, turn the unit OFF, let it cool completely, then inspect for maintenance and cleaning. It commonly accumulates along exhaust areas.

If creosote has formed within the unit, allow the unit to warm up at a low temperature, turn off the appliance, then wipe away any formation with a hand towel. Similar to tar, it is much easier to clean when warm, as it becomes liquid.

## **CARBON MONOXIDE (“THE SILENT KILLER”)**

Carbon monoxide is a colorless, odorless, tasteless gas produced by burning gas, wood, propane, charcoal or other fuel. Carbon monoxide reduces the blood’s ability to carry oxygen. Low blood oxygen levels can result in headaches, dizziness, weakness, nausea, vomiting, sleepiness, confusion, loss of consciousness or death. Follow these guidelines to prevent this colorless, odorless gas from poisoning you, your family, or others:

- See a doctor if you or others develop cold or flu-like symptoms while cooking or in the vicinity of the appliance. Carbon monoxide poisoning, which can easily be mistaken for a cold or flu, is often detected too late.
- Alcohol consumption and drug use increase the effects of carbon monoxide poisoning.

Carbon monoxide is especially toxic to mother and child during pregnancy, infants, the elderly, smokers, and people with blood or circulatory system problems, such as anemia, or heart disease.

## **SAFETY LISTING**

Conforms to EN 60335-2-102:2016, EN 60335-1:2012 + A11:2014 + A13:2017 + A1: 2019 + A14: 2019 + A2: 2019, EN62233: 2008, EN 55014-1:2017, EN IEC 61000-3-2:2019, EN 61000-3-3:2013+A1:2019, EN 55014-2:2015.





**COPYRIGHT NOTICE**

Copyright 2021. All right reserved. No part of this manual may be copied, transmitted, transcribed, stored in a retrieval system, in any form or by any means without expressed written permission of,

**Dansons**

3411 North 5th Avenue, Suite 500, Phoenix, AZ, USA 85013  
sales@pitboss-grills.com | service@pitboss-grills.com  
[www.pitboss-grills.com](http://www.pitboss-grills.com)

**Customer Service**

Monday through Sunday, 4am - 8pm PST (EN/FR/ES)  
**Toll-Free: 1-877-303-3134, Fax: 1-877-303-3135**

**TABLE OF CONTENTS**

- Safety Information ..... 2
- Parts & Specs..... 6
- Assembly Preparation ..... 7
- Assembly Instructions
  - Installing The Side Handles..... 7
  - Mounting The Legs To The Grill ..... 8
  - Assembling The Lid Handle ..... 8
  - Installing The Flame Broiler Components..... 8
  - Installing The Cooking Components ..... 9
  - Mounting The Power Cord Bracket ..... 9
  - Installing The Power Cord ..... 9
  - Attaching the Grease Cup ..... 9
  - Connecting To A Power Source..... 10
- Operating Instructions
  - Grill Environment ..... 11
  - Grill Temperature Ranges ..... 12
  - Understanding The Probes ..... 12
  - Understanding The Control Board ..... 13
  - Hopper Priming Procedure ..... 14
  - First Use – Grill Burn-Off ..... 14
  - Automatic Start-Up Procedure..... 14
  - Manual Start-Up Procedure ..... 15
  - Shutting Off Your Grill..... 15
- Care & Maintenance ..... 16
- Tips & Techniques ..... 17
- Troubleshooting ..... 18
- Electrical Wire Diagram ..... 20
- Replacement Parts..... 21
- Warranty ..... 22

# PARTS & SPECS

Part#	Description
1	Upper Cooking Rack (x1)
2	Cooking Grid (x1)
3	Flame Broiler Slider (x1)
4	Flame Broiler Main Plate (x1)
5	Flame Broiler Adjusting Bar Handle (x1)
6	Flame Broiler Adjusting Bar (x1)
7	Side Handle Bracket (x4)
8	Side Handle (x2)
9	Main Barrel/ Hopper Assembly (x1)
10	Power Cord Bracket (x1)
11	Lid Handle (x1)
12	Grease Cup (x1)
13	Foot A (x2)
14	Foot B (x2)
15	Power Cord Clip (x1)
16	Power Cord - F Plug (x1)
17	Power Cord - G Plug (x1)
18	Meat Probe (x1)

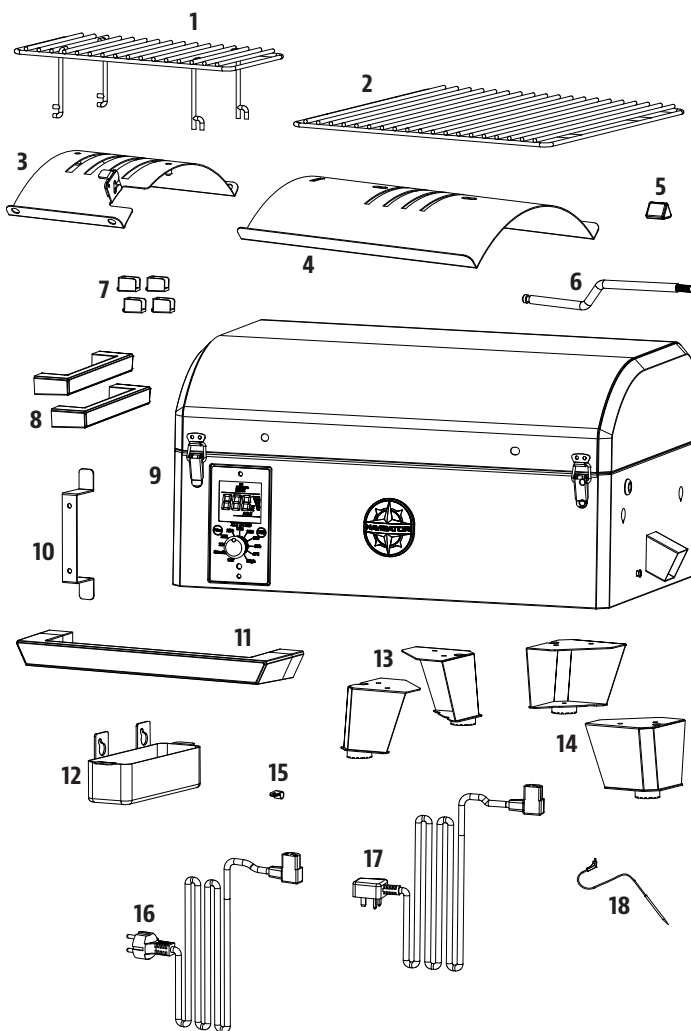

NOTE: Due to ongoing product development, parts are subject to change without notice. Contact Customer Service if parts are missing when assembling the unit.

**PB – ELECTRIC REQUIREMENTS**  
**220-240 V, 50 HZ, 220 W, 3-PRONG GROUNDED PLUG**

MODEL	UNIT ASSEMBLED (WxDxH)	UNIT WEIGHT	COOKING AREA	TEMPERATURE RANGE
<b>PB</b> PB150PPS	684 MM X 485 MM X 378 MM / 26.93 IN. X 19.09 IN. X 14.88 IN.	19.7 KG / 43.43 LB	MAIN - 1,235.86 CM <sup>2</sup> / 191.56 IN <sup>2</sup> UPPER RACK - 419.85 CM <sup>2</sup> / 65.0 IN <sup>2</sup> TOTAL - 1,655.71 CM <sup>2</sup> / 256.56 IN <sup>2</sup>	82-260°C / 180-500°F

# ASSEMBLY PREPARATION

Parts are located throughout the shipping carton, including underneath the grill. Inspect the grill, parts, and hardware blister pack after removing from the protective shipping carton. Discard all packaging materials from inside and outside of the grill before assembly, then review and inspect all parts by referencing the parts list. If any part is missing or damaged, do not attempt to assemble. Shipping damage is not covered under warranty. Contact your dealer or Pit Boss® Customer Service for parts: Monday through Sunday, 4am - 8pm PST (EN/FR/ES).

[service@pitboss-grills.com](mailto:service@pitboss-grills.com) | Toll-Free: 1-877-303-3134 | Toll-Free Fax: 1-877-303-3135

**IMPORTANT: To ease installation, using two people is helpful (but not necessary) when assembling this unit.**

**Tools required for assembly:** screwdriver and level. *Tools not included.*



# ASSEMBLY INSTRUCTIONS

**IMPORTANT: It is advised to read each step entirely before starting assembly on instructions. Do not tighten screws completely until all screws for that step have been installed.**

## 1. INSTALLING THE SIDE HANDLES

### Parts Required:

- 4 x Side Handle Bracket (#7)
- 2 x Side Handle (#8)
- 1 x Main Barrel/ Hopper Assembly (#9)

### Installation:

- Place a piece of cardboard on the floor to prevent scratching the unit and parts during assembly. Remove all the parts from inside the lid.
- Remove the pre-installed screws, locking washers and washers from the four Side Handle Brackets. Set aside.
- Remove the two pre-installed screws from the left side panel of the unit (on the hopper access panel). Secure two Side Handle Brackets to the left side panel using the same screws just removed. Repeat same installation for right side panel of the unit with the two other Side Handle Brackets. Note illustration 1A.
- Next, carefully flip the unit upside-down. Install each Side Handle into the Side Handle Brackets using the screws, locking washers, and washers previously removed from the Side Handle Brackets. Note illustration 1B.

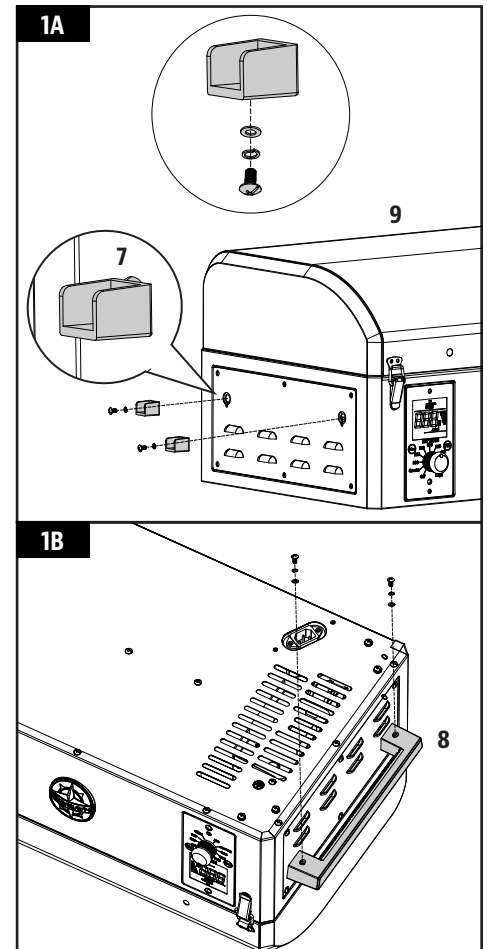

## 2. MOUNTING THE LEGS TO THE GRILL

### Parts Required:

- 1 x Main Barrel / Hopper Assembly (#9)
- 2 x Foot A (#13)
- 2 x Foot B (#14)

### Installation:

- Remove the eight pre-installed screws from the bottom panel corners of the unit, two from each corner.
- Secure Foot A to the bottom panel corner (closest to the control board) using two of the screws previously removed. Repeat same installation on opposite corner with other Foot A.
- Secure each Foot B on the two remaining bottom panel corners, using two screws in each.

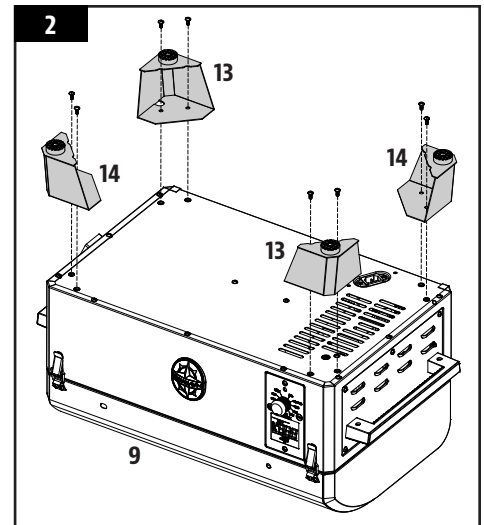

## 3. ASSEMBLING THE LID HANDLE

### Parts Required:

- 1 x Lid Handle (#11)

### Installation:

- Remove the pre-installed screws, locking washers and washers from the Lid Handle ends. Add a locking washer and washer onto a screw, then from inside the barrel lid, insert the screw so that it protrudes to the outside. Hand-tighten the screw (from the inside) into the Lid Handle. Repeat same installation for other end of Lid Handle.

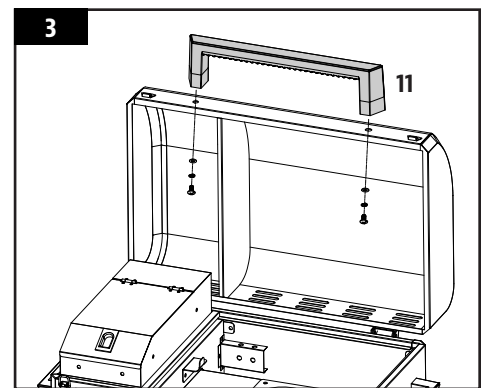

## 4. INSTALLING THE FLAME BROILER COMPONENTS

### Parts Required:

- 1 x Flame Broiler Slider (#3)
- 1 x Flame Broiler Main Plate (#4)
- 1 x Flame Broiler Adjusting Bar Handle (#5)
- 1 x Flame Broiler Adjusting Bar (#6)

### Installation:

- Insert the Flame Broiler Main Plate into the Main Barrel, left side first. Rest the Flame Broiler Main Plate slot onto the ledge tab on the left side, then rest the right side on the built-in ledge (on the inside right) of the Main Barrel that directs grease towards the Grease Cup. It will sit slightly at a downward angle. Note 4A.

**IMPORTANT: If the Flame Broiler Main Plate is on the base of the barrel, it is installed incorrectly. The Flame Broiler Main Plate should sit at an angle, with the left side sitting higher than the right. Poor installation of this part may result in damage to your Grill Barrel.**

- Place the Flame Broiler Slider on top of the Flame Broiler Main Plate, covering the slotted openings. Ensure the raised tab is on the right, to easily adjust for direct or indirect flame when cooking. Note illustration 4B. Both Flame Broiler parts are lightly coated with oil to avoid rusting when shipped.

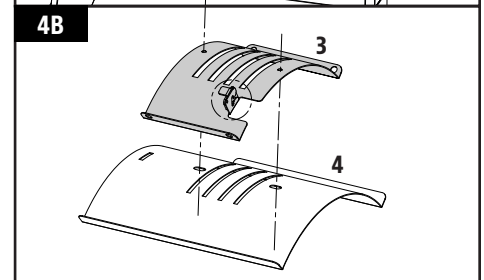
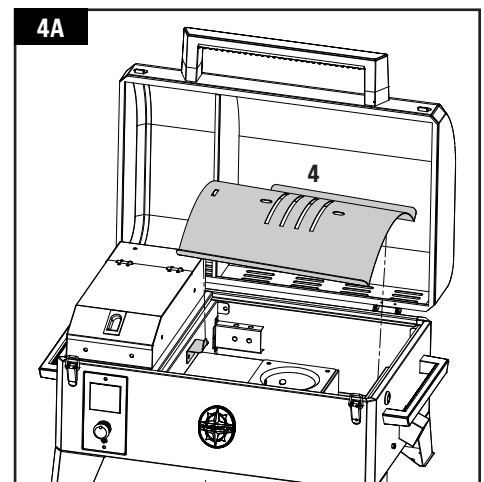



- Next, remove the Flame Broiler Adjusting Bar Handle from the Flame Broiler Adjusting Bar. Insert the Flame Broiler Adjusting Bar through the opening hole on the right side of the Main Barrel. Add the Flame Broiler Adjusting Bar Handle back onto the end outside the barrel. Next, slide the notched end of the Adjusting Bar into the locking tab on the Flame Broiler Slider, giving you adjustable access to the Flame Broiler Slider on the Main Plate. Note steps in 4C.

**NOTE: When the Flame Broiler Slider is open and direct flame is used, do not leave the grill unattended for any period of time.**

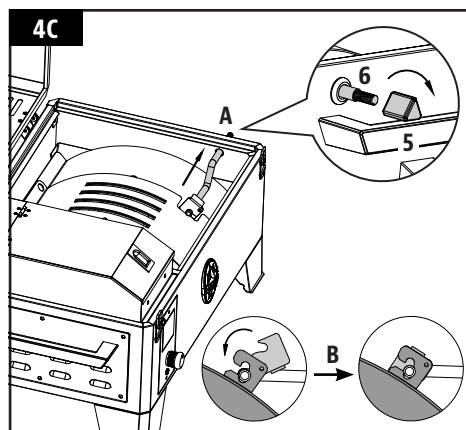

## 5. INSTALLING THE COOKING COMPONENTS

### Parts Required:

- 1 x Upper Cooking Rack (#1)
- 1 x Cooking Grid (#2)

### Installation:

- Place the Cooking Grid on the ledge inside the Main Grill.
- Position the Upper Cooking Rack onto the Cooking Grid. The Upper Cooking Rack can be placed as desired.

**NOTE: To maintain the searing and grilling performance of your cooking grids, regular care and maintenance is required.**

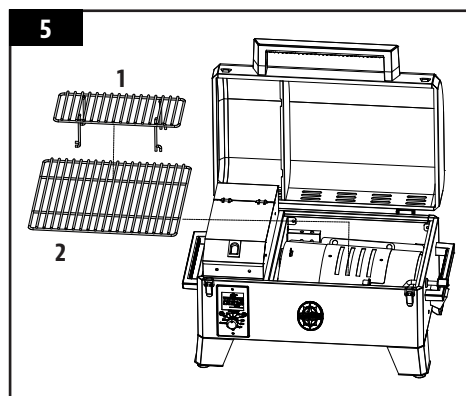

## 6. MOUNTING THE POWER CORD BRACKET

### Parts Required:

- 1 x Power Cord Bracket (#10)

### Installation:

- Remove the two pre-installed screws from the back panel of the unit. Secure the Power Cord Bracket to the corner by using the two screws previously removed.

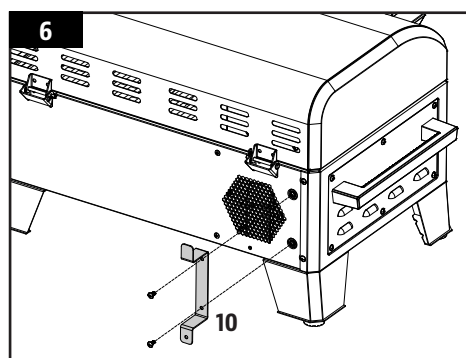

## 7. INSTALLING THE POWER CORD

*NOTE: There are two Power Cords supplied. Select the Power Cord that is required for your region.*

### Parts Required:

- 1 x Power Cord Clip (#15)
- 1 x Power Cord (#16 or #17)

### Installation:

- Place the Power Cord Clip on the Power Cord. Then, insert the Power Cord into the groove at the bottom of the unit. Note 7A.
- Secure the Power Clip to the rear panel using the pre-installed screw below the air vent. Note 7B.

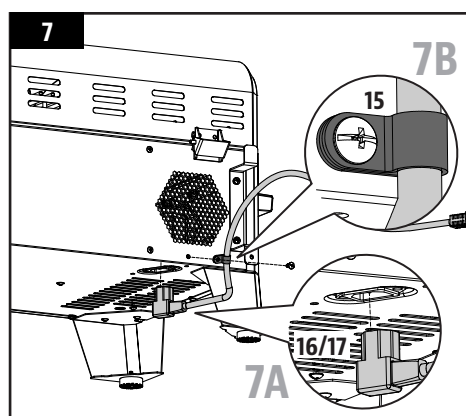

## 8. ATTACHING THE GREASE CUP

### Parts Required:

- 1 x Grease Cup (#12)

### Installation:

- Place the Grease Cup on the two screws of the pre-mounted screws of the Main Barrel side panel. Press down firmly to ensure it is level on the screws to avoid grease spills.
- The unit is now completely assembled.

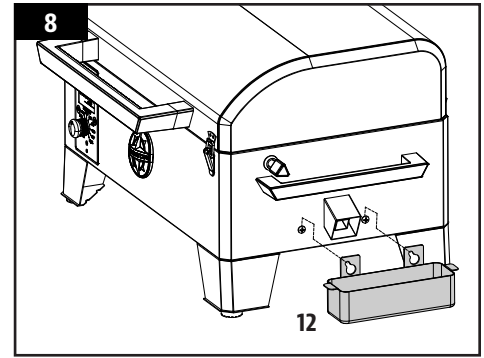

## 9. CONNECTING TO A POWER SOURCE

**NOTE:** Before plugging your Pit Boss® into any electrical outlet, ensure the temperature dial is in the OFF position.

- STANDARD OUTLET**  
This appliance requires 220-240 volt, 50 hz, 220 w. It must be a 3-prong grounded plug. Ensure grounded end is not broken off before use. The control uses a 220-240 volt and fast-blow fuse to protect the board from the ignitor.
- ON THE ROAD**  
Disconnect the igniter from the main wiring harness. Use the manual start-up procedure. A Pit Boss® unit can operate using a 12 volt, 100 watt inverter plugged into your automobile outlet. To use the automatic igniter, it is recommended to use a minimum of a 1000 watt inverter.

**IMPORTANT:** Disconnect unit from power source when not in use.

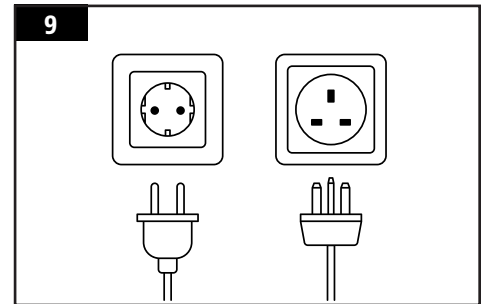

# OPERATING INSTRUCTIONS

*With today's lifestyle of striving to eat healthy and nutritious foods, one factor to consider is the importance of reducing fat intake. One of the best ways to cut down on fat in your diet is to use a low fat method of cooking, such as grilling. As a pellet grill uses natural wood pellets, the savory wood flavor is cooked into the meats, reducing the need for high sugar content sauces. Throughout this manual, you will notice the emphasis on grilling food slowly at LOW or MEDIUM temperature settings.*

## GRILL ENVIRONMENT

### 1. *WHERE TO SET-UP THE GRILL*

With all outdoor appliances, outside weather conditions play a big part in the performance of your grill and the cooking time needed to perfect your meals. All Pit Boss® units should keep a minimum clearance of 305mm (12 inches) from combustible constructions, and this clearance must be maintained while the grill is operational. This appliance must not be placed under overhead combustible ceiling or overhang. Keep your grill in an area clear from combustible materials, gasoline and other flammable vapors and liquids.

### 2. *COLD WEATHER COOKING*

As it becomes cooler outside, that does not mean that grilling season is over! The crisp cool air and heavenly aroma of smoked foods will help cure your winter blues. Follow these suggestions on how to enjoy your grill throughout the cooler months:

- If smoking at low temperatures fails, increase the temperature slightly to achieve the same results.
- Organize – Get everything you require ready in the kitchen before you head outdoors. During the winter, move your grill to an area that is out of the wind and direct cold. Check local bylaws regarding the proximity of your grill in relation to your home and/or other structures. Put everything you need on a cup, bundle up tight, and get it done!
- To help keep track of the outside temperature, place an outdoor thermometer close to your cooking area. Keep a log or history of what you cooked, the outdoor temperature, and the cooking time. This will help later down the road to help you determine what to cook and how long it will take.
- In very cold weather, increase your preheating time by at least 20 minutes.
- Avoid lifting the lid any more than necessary. Cold gusts of wind can completely cool your grill temperature. Be flexible with your serving time; add extra cooking time each time you open the lid.
- Have a heated platter or a dish cover ready to keep your food warm while making the trip back inside.
- Ideal foods for winter cooking are those that require little attention, such as roasts, whole chickens, ribs, and turkey. Make your meal preparation even easier by adding simple items such as vegetables and potatoes.

### 3. *HOT WEATHER COOKING*

As it becomes warmer outdoors, the cooking time will decrease. Follow these few suggestions on how to enjoy your grill throughout the hot months:

- Adjust your cooking temperatures downward. This helps to avoid unwanted flare-ups.
- Use a meat thermometer to determine the internal temperature of your foods. This helps in preventing your meat from over cooking and drying out.
- Even in hot weather it is still better to cook with the lid of your grill down.
- You can keep foods hot by wrapping them in foil, and placing them in an insulated cooler. Stuff crumpled up newspaper around the foil and this will keep food hot for 3 to 4 hours.

## GRILL TEMPERATURE RANGES

Temperature readouts on the control board may not exactly match the thermometer. All temperatures listed below are approximate and are affected by the following factors: outside ambient temperature, the amount and direction of wind, the quality of pellet fuel being used, the lid being opened, and the quantity of food being cooked.

- *HIGH TEMPERATURE (205-260°C / 401-500°F)*

This range is best used to sear and grill at a high heat. Use in tandem with the flame broiler (slide plate) for indirect or direct flame cooking. With the **flame broiler open**, direct flame is used to create those “blue” steaks, as well as flame-kissed vegetables, garlic toast or s’mores! When the **flame broiler is closed**, the air circulates around the barrel, resulting in convection heat. High temperature is also used to preheat your grill, burn-off the cooking grids, and to achieve high heat in extreme cold weather conditions.

- *MEDIUM TEMPERATURE (135-180°C / 275-356°F)*

This range is best for baking, roasting, and finishing off that slow smoked creation. Cooking at these temperatures will greatly reduce the chances of a grease flare-up. Ensure that the flame broiler slider is in the closed position, covering the slotted openings. Great range for cooking anything wrapped in bacon, or where you want versatility with control.

- *LOW TEMPERATURE (82-125°C / 180-257°F)*

This range is used to slow roast, increase smoky flavor, and to keep foods warm. Infuse more smoke flavor and keep your meats juicy by cooking longer at a lower temperature (also known as **low and slow**). Recommended for the big turkey at Thanksgiving, juicy ham at Easter, or the huge holiday feast.

Smoking is a variation on true barbecuing and is truly the main advantage of grilling on a wood pellet grill. **Hot smoking**, another name for **low and slow** cooking, is generally done between 82-125°C / 180-257°F. Hot smoking works best when longer cooking time is required, such as large cuts of meats, fish, or poultry.

**TIP: To intensify that savory flavor, switch to SMOKE (low) temperature range immediately after putting your food on the grill. This allows the smoke to penetrate the meats.**

The key is to experiment with the length of time you allow for smoking, before the meal is finished cooking. Some outdoor chefs prefer to smoke at the end of a cook, allowing the food to keep warm until ready to serve. Practice makes perfect!

## UNDERSTANDING THE PROBES

- *GRILL PROBE*

Located inside the main barrel, on the back-left wall, is the Grill Probe. It is a small, vertical piece of stainless steel. The Grill Probe measures the internal temperature of the unit. When the temperature is adjusted on the Control Board, the Grill Probe will read the actual temperature inside the unit and adjust to the desired temperature.









**IMPORTANT: The temperature of your unit is highly affected on ambient outdoor weather, quality of pellets used, flavor of pellets, and the quantity of food being cooked.**

- *MEAT PROBE*

The meat probe measures the internal temperature of your meat in the grill, similar to your indoor oven. Plug-in the meat probe adapter to the meat probe connection port on the Control Board and insert the stainless steel meat probe into the thickest portion of your meat and the temperature will be displayed on the control board. **To ensure the meat probe is connected properly to the connection port, feel and hear it snap into place.**

**NOTE: When placing the meat probe into your meat, ensure the meat probe and meat probe wires avoid direct contact with flame or excess heat. This can result in damage to your meat probe. When not in use, disconnect from the meat probe connection port and place aside to keep protected and clean.**

## UNDERSTANDING THE CONTROL BOARD

CONTROL	DESCRIPTION
	The LCD Screen is used as the information center for your unit. The LCD screen will display the current grill temperature (ACTUAL) and meat probe temperature (MP1). The flashing LCD screen indicates the unit was just connected to AC power. Screen flashes three times, then turns off.
	Indicates the meat probe temperature when probe is connected.
<b>Actual</b>	Indicates the current temperature of unit.
<b>Set</b>	Indicates the desired temperature that has been selected.
	Indicates the auger motor is turning and feeding pellets to the Burn Pot.
	Indicates the igniter is on. When first starting your unit, the igniter runs continuously for the start-up cycle.
	Indicates the fan is running. If the grill is in operation, the fan is on.
<b>NO PELLETS</b>	Indicates the auger motor is no longer able to feed pellets to the Burn Pot. Likely, the hopper is empty and requires refilling.
	Press and hold the Prime Button to activate an extra feed of pellets to the Burn Pot. This can be used to add more fuel to the fire just before opening the barrel lid, resulting in a quicker heat recovery time. It can also be used to add more fuel while smoking, to increase the intensity of clean smoke flavor. Overfeeding the Burn Pot may damage to grill barrel paint.
	The Temperature Switch Button is used to change the temperature readout on the LED Screen. Press the button to switch to Fahrenheit (°F) or to Celsius (°C), as preferred. Default is set to Celsius.
	The Temperature Control Dial allows you to set your desired temperature. Rotate the knob marker to select from Smoke, any of the eight temperature presets, or High. Once rotating the dial, the SET Temperature on the LCD Screen will adjust.
<b>OFF</b>	The Off Setting on the Temperature Control Dial is the OFF mode for the unit. The unit will not function on this setting.
<b>SMOKE</b>	The Smoke Setting on the Temperature Control Dial is the lowest smoking mode for the unit. The grill operates at the lowest temperature, without the fire going out.
<b>HIGH</b>	The High Setting on the Temperature Control Dial is the highest heat level for the unit. The grill operates at the highest temperature. When the lid is open, the grill will run at this speed to compensate for the loss of heat in the barrel.
	The plug-in connection port on the front of the Control Board is for a Meat Probe. When the meat probe is connected, the temperature is displayed on the LCD Screen. When the meat probe is not in use, disconnect the adapter from the connection port.



## HOPPER PRIMING PROCEDURE

These instructions should be followed the first time the grill is ignited, and each time the grill runs out of pellets in the hopper. The auger must be primed to allow pellets to travel through the length of the auger, and fill the Burn Pot. **If not primed, the igniter will timeout before the pellets are ignited, and no fire will start.** Follow these steps to prime the hopper:

1. Open the hopper lid. Make sure there are no foreign objects in the hopper or blocking the auger feed system at the bottom.
2. Remove all cooking components from the interior of the grill. Locate the Burn Pot in the bottom of the main barrel.
3. Plug the power cord into a power source. Press the Power Button to turn the unit on, and turn the Temperature Control Dial to the SMOKE position. Check the following items:
  - That you can hear the auger turning. Place your hand above the Burn Pot and feel for air movement. Do not place your hand or fingers inside the Burn Pot. This can cause injury.
  - After approximately a minute, you should smell the igniter burning and begin to feel the air getting warmer in the Burn Pot. The igniter tip does not glow red, but gets extremely hot and will burn. Do not touch the igniter.
4. Once verified that all electric components are working correctly, press the Power Button to turn the unit off.
5. Fill the hopper with all natural barbecue wood pellets.
6. Press the Power Button to turn the unit on. Keep the Temperature Control Dial in the SMOKE position. Press and hold the Prime Button until you see pellets on the inside of the grill from the auger tube. Once pellets begin to drop into the Burn Pot, release the Prime Button.
7. Press the Power Button to turn the unit off.
8. Re-install the cooking components into the main barrel. The grill is now ready to use.

## FIRST USE – GRILL BURN-OFF

Once your hopper has been primed and before cooking on your grill for the first time, it is important to complete a grill burn-off. Start the grill and operate at any temperature over 176°C / 350°F (with the lid down) for 30 to 40 minutes to burn-off the grill and rid it of any foreign matter.

## AUTOMATIC START-UP PROCEDURE

1. Plug the power cord into a grounded power source. Open the main barrel lid. Check the Burn Pot to ensure there is no obstruction for proper ignition. Open the hopper lid. Ensure there are no foreign objects in the hopper or auger feed system. Fill the hopper with dry, all natural barbecue hardwood pellets.
2. Ensure the Temperature Control Dial is in the SMOKE position. Press the Power Button to turn the unit on. This will activate the start-up cycle. The auger feed system will begin to turn, the igniter will begin to glow and the fan will supply air to the Burn Pot. The grill will begin to produce smoke while the start-up cycle is taking place. The barrel lid must remain open during the start-up cycle. To confirm the start-up cycle has begun properly, listen for a torchy roar, and notice some heat being produced.
3. Once the heavy, white smoke has dissipated, the start-up cycle is complete and you are ready to enjoy your grill at your desired temperature!

### IGNITER FAILURE PROCEDURE

If for any reason your electric igniter fails or your grill's flame dies out during a cook, check the following steps, or start your grill using the manual method.

1. Ensure the Temperature Control Dial is in the SMOKE position. Open the barrel lid. Remove the cooking components from inside. Remove all unburnt pellets and ash from the Burn Pot. Avoid touching the igniter to avoid injury, as it may be extremely hot.
2. Once all cooking components are removed and cleaned, press the Power Button to turn the unit on. Check the following:
  - Visually confirm that the igniter is working by placing your hand above the Burn Pot and feeling for heat.
  - Visually confirm that the igniter is protruding approximately 13mm / 0.5 inches in the Burn Pot.
  - Visually confirm that the auger is dropping pellets into the Burn Pot.
  - Confirm that the combustion fan is working by listening for a torchy roar.
3. If any of the above points are not working, follow **Troubleshooting** instructions.

### MANUAL START-UP PROCEDURE

1. Ensure the Temperature Control Dial is in the SMOKE position. Plug the power cord into a grounded power source.
2. Check Burn Pot to ensure there is no obstruction for proper ignition. Open the hopper lid. Ensure there are no foreign objects in the hopper or auger feed system. Fill hopper with dry, all natural hardwood barbecue pellets.
3. Open the barrel lid. Remove the cooking components to expose the Burn Pot. Place a generous handful of pellets into the Burn Pot. Squirt a gelled fire starter, or other appropriate pellet starter, over the top of the pellets. A small amount of solid fuel fire starter, such as one composed of sawdust and wax, or wood shavings, is also appropriate. Add another small amount of pellets in the Burn Pot.

**NOTE: Do not use spirit, petrol, gasoline, lighter-fluid or kerosene for lighting or refreshing a fire in your grill.**

4. Light the contents of the Burn Pot using a long match or long-nosed lighter. Allow the starter to burn for 3 to 5 minutes. Do not attempt to add more starter into the Burn Pot. This can cause injury.
5. Quickly and carefully replace the cooking components to the inside of the main barrel. Continue start-up at step two of **Automatic Start-Up Procedure**.

### SHUTTING OFF YOUR GRILL

1. When finished cooking, with the main barrel lid remaining closed, press the Power Button to turn the unit off and turn the Temperature Control Dial to OFF. The grill will begin its automatic cool-down cycle. The auger system will stop feeding fuel, the flame will burn out, and the fan will continue to run until the cool-down cycle is complete. When the cycle is complete, the fan will turn off.

# CARE AND MAINTENANCE

Any Pit Boss® unit will give you many years of flavorful service with minimum cleaning. Follow these cleaning and maintenance tips to service your grill:

## 1. HOPPER ASSEMBLY

- Running all pellets out of your auger system is recommended if your grill will be unused for an extended period of time. This can be done by simply running your grill, on an empty hopper, until all pellets have emptied from the auger tube.

**NOTE: Use a long handled brush or shop-vac to remove excess pellets, sawdust, and debris for a complete clean-out through the hopper screen.**

- Check and clean off any debris from the fan air intake vent, found on the bottom of the hopper. Once the hopper access panel is removed (see **Electric Wire Diagram** for diagram), carefully wipe off any grease build-up directly on the fan blades. This ensures airflow is sufficient to the feed system.

## 2. INSIDE SURFACES

- It is recommended to clean your Burn Pot after every few uses. This will ensure proper ignition and avoid any hard build-up of debris or ash in the Burn Pot.
- Use a long-handled grill cleaning brush, remove any food or build-up from the cooking grids. Best practice is to do this while they are still warm from a previous cook. Grease fires are caused by too much fallen debris on the cooking components of the grill. Clean the inside of your grill on a consistent basis. In the event you experience a grease fire, keep the grill lid closed to choke out the fire. If the fire does not go out quickly, carefully remove the food, turn the grill off, and shut the lid until the fire is completely out. Lightly sprinkle baking soda, if available.
- Check your grease cup often, and clean out as necessary. Keep in mind the type of cooking you do.

## 3. OUTSIDE SURFACES

- Wipe your grill down after each use. Use warm soapy water to cut the grease. Do not use oven cleaner, abrasive cleansers or abrasive cleaning pads on the outside grill surfaces. **All painted surfaces are not covered under warranty**, but rather are part of general maintenance and upkeep. For paint scratches, wearing, or flaking of the finish, all painted surfaces can be touched up using high heat BBQ paint.
- Use a grill cover to protect your grill for complete protection! A cover is your best protection against weather and outside pollutants. When not in use or for longterm storage, keep the unit under a cover in a garage or shed.

### CLEANING FREQUENCY TIME TABLE (NORMAL USE)

ITEM	CLEANING FREQUENCY	CLEANING METHOD
Bottom of Main Grill	Every 5-6 Grill Sessions	Scoop Out, Shop-Vac Excess Debris
Burn Pot	Every 2-3 Grill Sessions	Scoop Out, Shop-Vac Excess Debris
Cooking Grids	After Each Grill Session	Burn Off Excess, Grill Cleaning Brush
Flame Broiler	Every 5-6 Grill Sessions	Scrape Main Plate with Slider, Do Not Wash Clean
Grease Cup	After Each Grill Session	Scrub Pad & Soapy Water
Auger Feed System	When Pellet Bag is Empty	Allow Auger to Push Out Sawdust, Leaving Hopper Empty
Hopper Electric Components	Once A Year	Dust Out Interior, Wipe Fan Blades with Soapy Water
Air Intake Vent	Every 5-6 Grill Sessions	Dust, Scrub Pad & Soapy Water
Grill Probe	Every 2-3 Grill Sessions	Scrub Pad & Soapy Water



## TIPS & TECHNIQUES

Follow these helpful tips and techniques, passed on from Pit Boss® owners, our staff, and customers just like you, to become more familiar with your grill:

### 1. *FOOD SAFETY*

- Keep everything in the kitchen and cooking area clean. Use different platters and utensils for the cooked meat than the ones you used to prepare or transport the raw meat out to the grill. This will prevent cross contamination of bacteria. Each marinade or basting sauce should have its own utensil.
- Keep hot foods hot (above 60°C / 140°F), and keep cold foods cold (below 3°C / 37°F).
- A marinade should never be saved to use at a later time. If you are going to use it to serve with your meat, be sure to bring it to a boil before serving.
- Cooked foods should not be left out in the heat for more than an hour. Do not leave hot foods out of refrigeration for more than two hours.
- Defrost and marinate meats by refrigeration. Do not thaw meat at room temperature or on a counter top. Bacteria can grow and multiply rapidly in warm, moist foods. Wash hands thoroughly with hot, soapy water before starting any meal preparation and after handling fresh meat, fish and poultry.

### 2. *COOKING PREPARATION*

- Be prepared, or **Mise en Place**. This refers to preparing the cooking recipe, fuel, accessories, utensils, and all ingredients you require at grill side before you start cooking. Also, read the entire recipe, start to finish, before lighting the grill.
- A BBQ floor mat is very useful. Due to food handling accidents and cooking spatter, a BBQ floor mat would protect a deck, patio, or stone platform from the possibility of grease stains or accidental spills.

### 3. *GRILLING TIPS AND TECHNIQUES*

- To infuse more smoke flavor into your meats, cook longer and at lower temperatures (also known as **low and slow**). Meat will close its fibers after it reaches an internal temperature of 49°C / 120°F. Misting, or mopping, are great ways to keep meat from drying out.
- While searing your meats, cook with the lid down. Always use a meat thermometer to determine the internal temperature of the foods you are cooking. Smoking foods with hardwood pellets will turn meats and poultry pink. The band of pink (after cooking) is referred to as a **smoke ring** and is highly prized by outdoor chefs.
- Sugar-based sauces are best applied near the end of cooking to prevent burning and flare-ups.
- Leave open space between the foods and the extremities of the barrel for proper heat flow. Food on a crowded grill will require more cooking time.
- Use a set of long-handled tongs for turning meats, and a spatula for turning burgers and fish. Using a piercing utensil, such as a fork, will prick the meat and allow the juices to escape.
- Foods in deep casserole dishes will require more time to cook than a shallow baking pan.
- It's a good idea to put cooked food onto a heated platter, keeping the food warm. Red meats, such as steak and roasts, benefit from resting for several minutes before serving. It allows the juices that were driven to the surface by heat to ease back to the center of the meat, adding more flavor.

# TROUBLESHOOTING

Proper cleaning, maintenance and the use of clean, dry, quality fuel will prevent common operational problems. When your Pit Boss® grill is operating poorly, or on a less frequent basis, the following troubleshooting tips may be helpful. For FAQ, please visit [www.pitboss-grills.com](http://www.pitboss-grills.com). You may also contact your local Pit Boss® authorized dealer or contact Customer Service for assistance.

**WARNING: Always disconnect the electrical cord prior to opening the grill for any inspection, cleaning, maintenance or service work. Ensure the grill is completely cooled to avoid injury.**

PROBLEM	CAUSE	SOLUTION
No Power Lights On The Control Board	Temperature Control Dial is still off.	Turn the Temperature Control Dial to a temperature setting.
	Not Connected To Power Source	Ensure unit is plugged into a working power source. Reset breaker. Ensure GFCI is a minimum 10 Amp service (see <b>Electric Wire Diagram</b> for access to electric components) Ensure all wire connections are firmly connected and dry.
	Fuse Blown On The Control Board	Remove hopper access panel (see <b>Electric Wire Diagram</b> for diagram), press in plastic tabs holding the control board in place and carefully pull controller inside the hopper to release controller. Check the fuse for a broken wire or if the wire has turned black. If yes, fuse needs to be manually replaced.
	Faulty Control Board	Control Board needs to be replaced. Contact Customer Service for a replacement part.
Fire in Burn Pot Will Not Light	Auger Not Primed	Before the unit is used for the first time or anytime the hopper is completely emptied out, the auger must be primed to allow pellets to fill the auger tube. If not primed, the igniter will timeout before the pellets reach the Burn Pot. Follow <b>Hopper Priming Procedure</b> .
	Auger Motor Is Jammed	Remove cooking components from the main barrel. Press the Power Button to turn the unit on, turn Temperature Control Dial to SMOKE, and inspect the auger feed system. Visually confirm that the auger is dropping pellets into the Burn Pot. If not operating properly, call Customer Service for assistance.
	Igniter Failure	Remove cooking components from the main barrel. Press the Power Button to turn the unit on, turn Temperature Control Dial to SMOKE, and inspect the igniter. Visually confirm that the igniter is working by placing your hand above the Burn Pot and feeling for heat. Visually confirm that the igniter is protruding approximately 13mm / 0.5 inches in the Burn Pot. If not operating properly, follow <b>Manual Start-up Procedure</b> to continue use of grill; however, call Customer Service for assistance or a replacement part.
	Insufficient Air Flow Through Burn Pot	Check Burn Pot for ash build-up or obstructions. Follow Care and Maintenance instructions for ash build-up. Check fan. Ensure it is working properly and air intake is not blocked. Follow <b>Care and Maintenance</b> instructions if dirty.
Flashing Dots On LCD Screen	The Igniter Is On	This is not an error that effects the grill. Used to show that the unit has power and is in Start-Up mode (igniter is on). The igniter will turn off after five minutes. Once the flashing dots disappear, the grill will begin to adjust to the desired temperature selected.
Flashing Temperature On LCD Screen	Grill Temperature Is Below 65°C /150°F	This is not an error that effects the unit; however, it is used to show that there is some risk that the fire could go out. Check hopper for sufficient fuel or if there is an obstruction in the feed system. Remove pellets and follow <b>Care and Maintenance</b> instructions. Check grill Grill Probe and follow <b>Care and Maintenance</b> instructions if dirty. Check Burn Pot for ash build-up or obstructions, and follow <b>Care and Maintenance</b> instructions for ash build-up. Check fan. Ensure it is working properly and air intake is not blocked. Follow <b>Care and Maintenance</b> instructions if dirty. Check auger motor to confirm operation (rotation), and ensure there is no blockage in the auger tube.

"ErH" Error Code	The Unit Has Overheated, Possibly Due To Grease Fire Or Excess Fuel.	Press the Power Button to turn the unit off, and allow grill to cool. Follow <b>Care and Maintenance</b> instructions. After maintenance, remove pellets, and confirm positioning of all component parts. Once cooled, press the Power Button to turn the unit on, then select desired temperature. If error code still displayed, contact Customer Service.
"Er1" Error Code	Grill Probe wire not making connection.	Remove hopper access panel (see <b>Electric Wire Diagram</b> for diagram), and check for any damage to the Grill Probe wires. Ensure Grill Probe molex connectors are firmly connected, and connected correctly, to the Control Board.
"ErP" Error Code	Unit Not Turned Off Properly When Last Connected To Power.	Safety feature prevents an automatic restart. Press the Power Button to turn the unit off, wait two minutes, then press the Power Button to turn the unit on again. Turn Temperature Control Dial to SMOKE or desired temperature. If error code still displayed, contact Customer Service.
	Power Outage While Unit In Operation.	
"noP" Error Code	Bad Connection At Connection Port	Disconnect meat probe from connection port on the Control Board, and reconnect. Ensure the meat probe adapter is firmly connected. Check for signs of damage to the adapter end. If still failed, call Customer Service for replacement part.
	Meat Probe Damaged	Check for signs of damage to the wires of the meat probe. If damaged, call Customer Service for replacement part.
	Faulty Control Board	Control Board needs to be replaced. Contact Customer Service for a replacement part.
Grill Will Not Achieve Or Maintain Stable Temperature	Insufficient Air Flow Through Burn Pot	Check Burn Pot for ash build-up or obstructions. Follow <b>Care and Maintenance</b> instructions for ash build-up. Check fan. Ensure it is working properly and air intake is not blocked. Follow <b>Care and Maintenance</b> instructions if dirty. Check auger motor to confirm operation, and ensure there is no blockage in the auger tube. Once all the above steps have been done, start the grill, set temperature to SMOKE and wait for 10 minutes. Check that the flame produced is bright and vibrant.
	Lack Of Fuel, Poor Fuel Quality, Obstruction In Feed System	Check hopper to check that fuel level is sufficient, and replenish if low. Should the quality of wood pellets be poor, or the length of the pellets too long, this may cause an obstruction in the feed system. Remove pellets and follow <b>Care and Maintenance</b> instructions.
	Grill Probe	Check status of Grill Probe. Follow <b>Care and Maintenance</b> instructions if dirty. Contact Customer Service for a replacement part if damaged.
Grill Produces Excess Or Discolored Smoke	Grease Build-Up	Follow <b>Care and Maintenance</b> instructions.
	Wood Pellet Quality	Remove moist wood pellets from hopper. Follow <b>Care and Maintenance</b> instructions to clean out. Replace with dry wood pellets.
	Burn Pot Is Blocked	Clear Burn Pot for ash and other debris. Follow <b>Hopper Priming Procedure</b> .
	Insufficient Air Intake For Fan	Check fan. Ensure it is working properly and air intake is not blocked. Follow <b>Care and Maintenance</b> instructions if dirty.
Frequent Flare-Ups	Cooking Temperature	Attempt cooking at a lower temperature. Grease does have a flash point. Keep the temperature under 176°C / 350°F when cooking highly greasy food.
	Grease Build-Up On Cooking Components	Follow <b>Care and Maintenance</b> instructions.

# ELECTRICAL WIRE DIAGRAM

The Digital Control Board system is an intricate and valuable piece of technology. For protection from power surges and electrical shorts, consult the wire diagram below to ensure your power source is sufficient for the operation of the unit.

**PB – ELECTRIC REQUIREMENTS**  
220-240 V, 50 Hz, 220 W, 3-PRONG GROUNDED PLUG

NOTE: Electrical components, passed by product safety testing and certification services, comply with a testing tolerance of ± 5-10 percent.

LOCATE AND REMOVE THE SIX SCREWS OF ACCESS PANEL ON LEFT SIDE OF UNIT

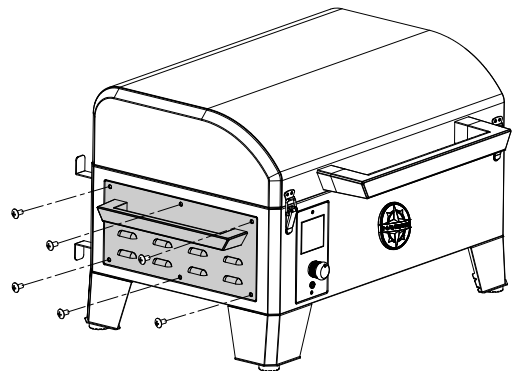

**FUEL INPUT RATING:**  
0.5 KG/H  
(1.1 LB/H)

## DIGITAL CONTROL BOARD

FAST-BLOW FUSE  
5 AMP

GRILL PROBE

MALE ADAPTER

GROUNDED POWER CORD

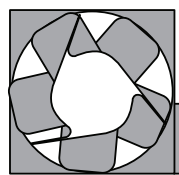

**DRAFT FAN**  
230 V, 50 Hz,  
1 PHASE

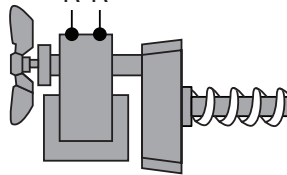

**AUGER MOTOR & FEED SYSTEM**  
230 V, 50 Hz,  
2 RPM MOTOR

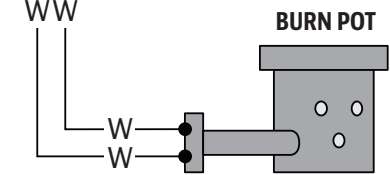

**IGNITER ASSEMBLY / HD CARTRIDGE HEATER**  
200 W, 230 V,  
9.5MM X 127MM  
(0.375" X 5.000")

### INDEX

- W : WHITE
- Y : YELLOW
- P : PURPLE
- R : RED
- K : BLACK
- S : SILVER
- G : GREEN

# REPLACEMENT PARTS

Part#	Description
1	Lid (x1)
2	Hasp (x2)
3	Bezel with Bolt (x2)
4	Lid Handle (x1)
5	Lid Hinge (x2)
6	Upper Cooking Rack (x1)
7	Cooking Grid (x1)
8	Flame Broiler Slider (x1)
9	Flame Broiler Main Plate (x1)
10	Flame Broiler Adjusting Bar (x1)
11	Flame Broiler Adjusting Bar Handle (x1)
12	Flame Broiler Hanger Bracket (x1)
13	Grill Probe Shield (x1)
14	Grill Probe (x1)
15	Hopper Lid (x1)
16	Hopper Safety Screen (x1)
17	Hopper Lid Switch (x1)
18	Hopper Box Housing (x1)
19	Hopper Guide Plate (x1)
20	Combustion Fan (x1)
21	Auger Motor (x1)
22	Nylon Bushing (x1)
23	Auger Fighting Assembly (x1)
24	Igniter (x1)
25	Burn Pot (x1)
26	Side Handle (x2)
27	Side Handle Bracket (x4)
28	Hopper Access Panel (x1)
29	Firebox / Body (x1)
30	R Pin (x2)
31	Hinge B (x2)
32	Body Hinge (x2)
33	Pin (x2)
34	Power Cord Bracket (x1)
35	Control Board (x1)
36	Rubber Ring (x1)
37	Grease Cup (x1)
38	Power Cord Waterproof Cover (x1)
39	Male Adapter (x1)

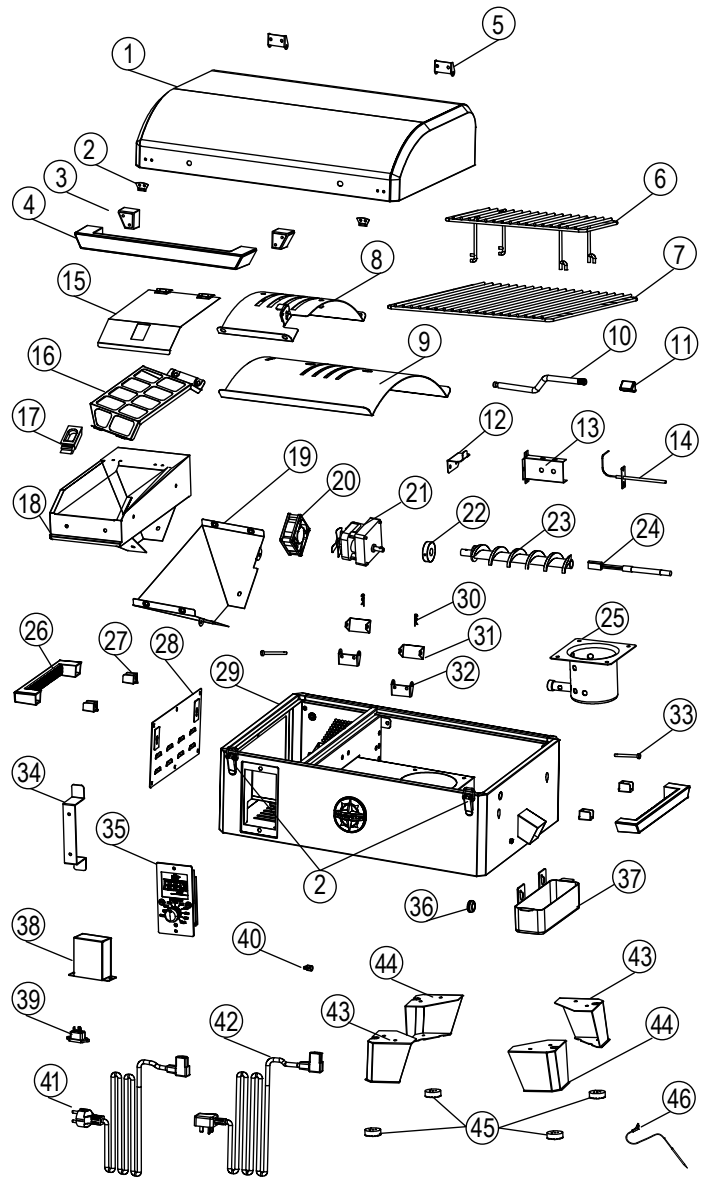

Part#	Description
40	Power Cord Clip (x1)
41	Power Cord - F Plug (x1)
42	Power Cord - G Plug (x1)
43	Foot A (x2)
44	Foot B (x2)
45	Foot Gasket (x4)
46	Meat Probe (x1)

# WARRANTY

## CONDITIONS

All wood pellet grills by Pit Boss®, manufactured by Dansons, carry a limited warranty from the date of sale by the original owner. The warranty coverage begins on the original date of purchase and proof of date of purchase, or copy of original bill of sale, is required to validate the warranty. Customers will be subject to parts, shipping, and handling fees if unable to provide proof of purchase or after the warranty has expired. Dansons carries a five (5) year warranty against defects and workmanship on all steel parts, and five (5) years on electrical components. Dansons warrants that all part(s) are free of defects in material and workmanship, for the length of use and ownership of the original purchaser. There is no specific warranty on the Grill Probe, meat probe, paint, powder coat finish, burn pot, grill cover and all gaskets or against damage caused from corrosion. Warranty does not cover damage from wear and tear, such as scratches, dents, dings, chips or minor cosmetic cracks. These aesthetic changes of the grill do not affect its performance. Repair or replacement of any part does not extend past the limited warranty.

During the term of the warranty, Dansons' obligation shall be limited to furnishing a replacement for defective and/or failed components. As long as it is within the warranty period, Dansons' will not charge for repair or replacement for parts returned, freight prepaid, if the part(s) are found by Dansons' to be defective upon examination. Dansons' shall not be liable for transportation charges, labor costs, or export duties. Except as provided in these conditions of warranty, repair or replacement of parts in the manner and for the period of time mentioned heretofore shall constitute the fulfillment of all direct and derivative liabilities and obligations from Dansons to you.

Dansons takes every precaution to utilize materials that resist rust. Even with these safeguards, the protective coatings can be compromised by various substances and conditions beyond Dansons' control. High temperatures, excessive humidity, chlorine, industrial fumes, fertilizers, lawn pesticides and salt are some of the substances that can affect metal coatings. For these reasons, the warranty does not cover rust or oxidation, unless there is loss of structural integrity on the grill component. Should any of the above occur, kindly refer to the care and maintenance section to prolong the lifespan of your unit. Dansons recommends the use of a grill cover when the grill is not in use. This warranty is based on normal domestic use and service of the grill, and neither limited warranty coverage's apply for a grill which is used in commercial applications.

## EXCEPTIONS

There is no written or implied performance warranty on Pit Boss® units, as the manufacturer has no control over the installation, operation, cleaning, maintenance or the type of fuel burned. This warranty will not apply nor will Dansons assume responsibility if your appliance has not been installed, operated, cleaned and maintained in strict accordance with this owner's manual. Burning other than quality wood pellets may void the warranty. The warranty does not cover damage or breakage due to misuse, improper handling or modifications. Neither Dansons, or authorized Pit Boss® dealer, accepts responsibility, legal or otherwise, for the incidental or consequential damage to the property or persons resulting from the use of this product. Whether a claim is made against Dansons based on the breach of this warranty or any other type of warranty expressed or implied by law, the manufacturer shall in no event be liable for any special, indirect, consequential or other damages of any nature whatsoever in excess of the original purchase of this product. All warranties by manufacturer are set forth herein and no claim shall be made against manufacturer on any warranty or representation. Some states do not allow the exclusion or limitation of incidental or consequential damages, or limitations of implied warranties, so the limitations or exclusions set forth in this limited warranty may not apply to you. This limited warranty gives you specific legal rights and you may have other rights, which vary from state to state.

## ORDERING REPLACEMENT PARTS

To order replacement parts, please contact your local Pit Boss® dealer or visit our online store at: [www.pitboss-grills.com](http://www.pitboss-grills.com)

## CONTACT CUSTOMER SERVICE

If you have any questions or problems, contact Customer Service, Monday through Sunday, 4am - 8pm PST (EN/FR/ES).

[service@pitboss-grills.com](mailto:service@pitboss-grills.com) | Toll-Free: 1-877-303-3134 | Toll-Free Fax: 1-877-303-3135

## WARRANTY SERVICE

Contact your nearest Pit Boss® dealer for repair or replacement parts. Dansons requires proof of purchase to establish a warranty claim; therefore, retain your original sales receipt or invoice for future reference. The serial and model number of your Pit Boss® can be found on the lid of the hopper. Record numbers below as the label may become worn or illegible.

---

MODEL

---

SERIAL NUMBER

---

DATE OF PURCHASE

---

AUTHORIZED DEALER



## IMPORTANT

### DO NOT RETURN PRODUCT TO STORE

For all questions, comments, or inquiries, please contact Dansons directly. Our Customer Service department is available Monday through Sunday, 4am - 8pm PST (EN/FR/ES).

**TOLL FREE: 1-877-303-3134**

**TOLL FREE FAX: 1-877-303-3135**

## IMPORTANT

### NE RETOURNEZ PAS LE PRODUIT AU MAGASIN

Pour toute questions, commentaires ou demandes de renseignements, veuillez communiquer avec Dansons directement. Le service à la clientèle est ouvert du lundi au dimanche, de 4 h à 20 h HP (ANG / FR / ES).

**NUMÉRO SANS FRAIS : 1-877-303-3134**

**TÉLÉCOPIEUR SANS FRAIS : 1-877-303-3135**

## ¡¡IMPORTANTE!

### NO DEVUELVA EL PRODUCTO A LA TIENDA

Para el preguntas, comentarios o consultas, por favor contactar Dansons directamente. Nuestro departamento de servicio al cliente está disponible lunes a viernes de 4:00 a.m. a 8:00 p.m. tiempo del Pacífico.

**LLAMADA GRATUITA: 1-877-303-3134**

**FAX GRATUITO: 1-877-303-3135**

## WICHTIG

### PRODUKT NICHT INS LAGER ZURÜCKSCHICKEN

Bei Fragen, Kommentaren oder Anfragen wenden Sie sich bitte direkt an Dansons. Unsere Kundendienstabteilung ist montags bis sonntags von 4 bis 20 Uhr PST (EN/FR/ES) erreichbar.

**GEBÜHRENFREI: 1-877-303-3134**

**GEBÜHRENFREIES FAX: 1-877-303-3135**

## IMPORTANTE

### NON RESTITUIRE QUESTO PRODOTTO AL NEGOZIO

Per ogni domanda, commento o richiesta, rivolgersi direttamente a Dansons. Il nostro ufficio per l'Assistenza alla clientela è a disposizione da lunedì a domenica, dalle 4 alle 20, fuso orario Pacifico (inglese/francese/spagnolo).

**NUMERO VERDE: 1-877-303-3134**

**NUMERO VERDE FAX: 1-877-303-3135**

MADE IN CHINA | FABRIQUÉ EN CHINE | HECHO EN CHINA  
IN CHINA HERGESTELLT | FABBRICATO IN CINA



780210309UMV

